

# SPECIFICATION

## BIZZOCCHI 620 HR

- Telescopic boom (5 elements) (main boom + 4 extensions) • Extra long main jib with double extension and 180° swivelling angle • Secondary jib with 180° swivelling angle • Hydraulic and electric supply fitted on cable carrier chain inside main boom and jib • Automatic management system of secondary jib movements • 570° slewing turret on bearing turntable and gearmotor with negative hydraulic brake • Ground control station with remote umbilical cord controls • Turret and basket control station with multifunctions integrated display • Proportional electrohydraulic controls with simultaneous manoeuvres (ergonomic joysticks) • Vehicle cab anticollision devices • Automatic basket and boom centring device • Automatic steady tangential speed management system • Automatic return to transport position • Intercom communication device integrated on control station • Engine start/stop control from basket and ground • Hydraulically extendable (2400/3600 x 900 x 1100 mm) aluminium basket • 90° Right + 90° Left hydraulic rotating basket • Electronic basket levelling • Automatic limiting device controlling outreach according to basket weight and stabiliser configuration • Auxiliary stand-by electro-hydraulic power pack, supplied by truck battery • Water or compressed air socket in the basket • 230V AC CE Electric socket in the basket

### PERFORMANCES

Working height	61,6 m	Working outreach	35,0/29,2 m
Platform height	59,6 m	Installation on 32t GVW chassis	
Capacity	120/450 kg		

### PLATFORM DIMENSIONS

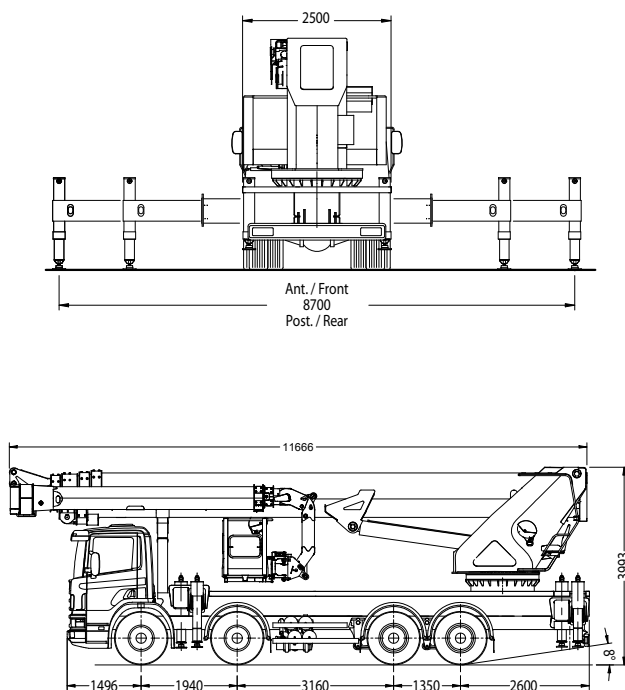

### WORKING AREA

